

1.1.2.7 High Power Thermal Sensors

1.1.2.7.3 High Power Water / Air / Conduction Cooled Thermal Sensors

1W to 2000W

Features

- Very large aperture
- Broadband or Pulsed absorber
- Up to 2000W
- Ø120mm aperture

L2000W-BB-120 / L2000W-PF-120



L100(500)A-PF-120



Model	L2000W-BB-120	L2000W-PF-120	L100(500)A-PF-120
Use	Very large beams	Very large beams, short pulses, high average power	High peak power, high energy measurements
Absorber Type	Broadband	PF volume absorber	PF volume absorber
Spectral Range μm	0.19 – 20	0.3 – 2.2	0.15 – 20
Aperture mm	Ø120mm	Ø120mm	Ø120mm
Power Mode			
Power Range	1W – 2000W	1W – 2000W	1W – 500W
Maximum Intermittent Power	NA	NA	500W for 2min, 100W continuous, 500W continuous if heat sunked on rear
Power Scales	2000W / 200W	2000W / 200W	500W / 50W
Power Noise Level	50mW	50mW	50mW
Maximum Average Power Density W/cm^2	700 at 1000W, 150 at 1500W, 60 at 2000W	600	2000
Response Time with Meter (0-95%) typ. s	7	7	7
Calibration Uncertainty $\pm\%$	1.9	1.9	1.9
Power Accuracy $\pm\%$	3 ^(a)	3 ^(a)	4 ^(a)
Linearity with Power $\pm\%$	2	2	2
Energy Mode			
Energy Range	6J – 6000J	6J – 6000J	6J – 6000J
Energy Scales	6kJ / 600J / 60J	6kJ / 600J / 60J	6kJ / 600J / 60J
Minimum Energy	6J	6J	6J
Maximum Energy Density J/cm^2		Single 10 – 50Hz ^(c)	Single 10-50Hz ^(c)
<100ns	0.3	3 ^(d) 1.5	3 ^(d) 1.5
1 μs	0.4	3 ^(d) 1.5	3 ^(d) 1.5
0.5ms	5	7 7	7 7
2ms	10	15 15	15 15
10ms	30	40 40	40 40
1s	4000	3000 NA	3000 NA
Cooling	water	water	convection or conduction
Minimum and Recommended Water Flow Rate at Full Power	3.5 liter/min 6 liter/min ^(b)	3.5 liter/min 6 liter/min ^(b)	NA
Fiber Adapters	Consult Ophir representative	Consult Ophir representative	Consult Ophir representative
Accessories for High Power Sensors	See pages 99-102	See pages 99-102	See pages 99-102
Weight kg	4.5	4.5	4.4
Compliance	CE, UKCA, China RoHS	CE, UKCA, China RoHS	CE, UKCA, China RoHS
Version			
Part number	7Z02751	7Z02792	7Z02765
Notes: (a)	Calibrated for $\sim 0.8\mu\text{m}$, $1.064\mu\text{m}$ and $10.6\mu\text{m}$	Calibrated for $1.07\mu\text{m}$. Max additional error at other wavelengths not specified above: $\pm 1\%$	Calibrated for $0.25 - 2\mu\text{m}$
Notes: (b)	Water temperature range 18-30°C. Water temperature rate of change $< 1^\circ\text{C}/\text{min}$. Pressure drop across sensor 0.06MPa.	Water temperature range 18-30°C. Water temperature rate of change $< 1^\circ\text{C}/\text{min}$. Pressure drop across sensor 0.06MPa.	
Notes: (c)		For 10-50Hz derate as follows: 1064nm not derated 532nm not derated 355nm 70% of stated value 266nm 15% of stated value 193nm 10% of stated value	For 10-50Hz derate as follows: 1064nm not derated 532nm not derated 355nm 70% of stated value 266nm 15% of stated value 193nm 10% of stated value
Notes: (d)		Damage threshold $1.5\text{J}/\text{cm}^2$ for wavelengths $< 500\text{nm}$	Damage threshold $1.5\text{J}/\text{cm}^2$ for wavelengths $< 500\text{nm}$

* For drawings please see page 84

L2000W-BB-120 / L2000W-PF-120

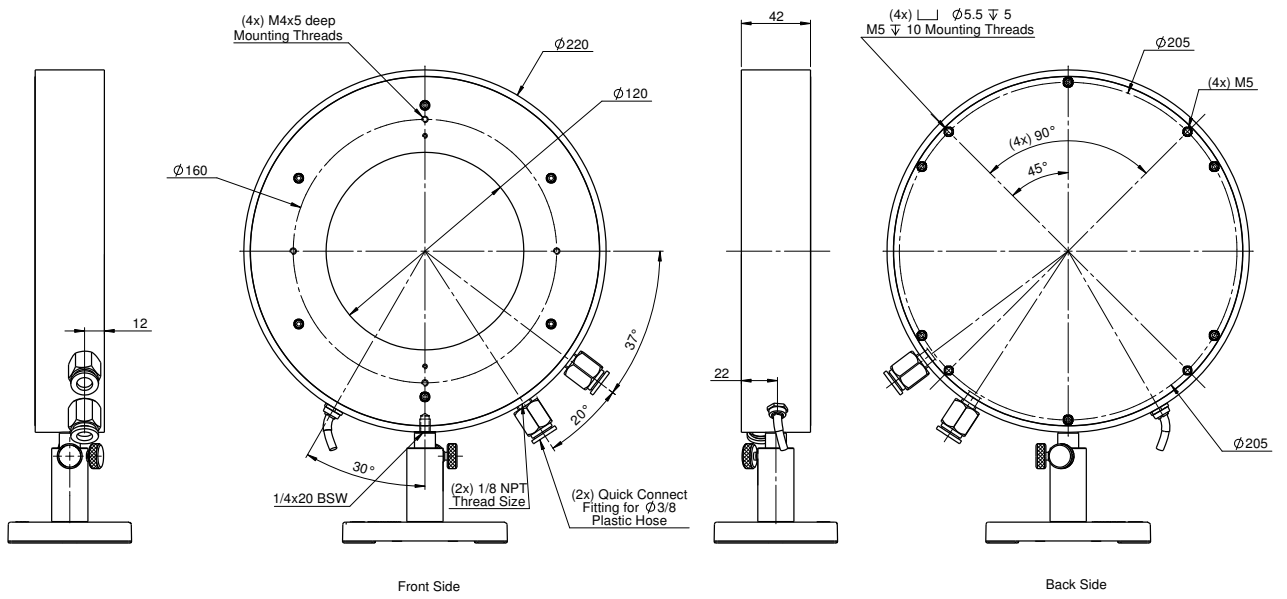

L100(500)A-PF-120

